

modular



FabricPopUp.com

0845 470 0845

contents

<9m² Stands

9m² - 12m² Stands

15m² - 25m² Stands

Reconfigurable

30m² + Stands

Introduction

Exhibitions are one of the best ways to showcase your company and its product range whilst reaching your target audience with face to face interaction.

Your stand will need to make an immediate impression and catch the attention of passers by whilst at the same time stand apart from your competitors.

Modular exhibition stands can be on the grandest scale or simple in their design – either way they can be impressive yet cost effective. The beauty of Modular stand designs is that they are flexible, re-configurable and most importantly re-usable, meaning you have total freedom to re-create your existing stand to use time and time again whilst maximising your ROI.

Build a wide range stand styles using a choice of Linear/Vector, Vector Lite, T3, Arena 4 Gantry, Panel and Pole, Formulate and portable display products.



You can choose from a wide selection of stand designs throughout this brochure, or talk to our 3D Design team who will work with you to create a stand that will impress everyone who sees it.

reconfigurable
flexible
reusable
modular
custom
portable



design
service



We can even make wooden
crates to protect your investment.

Reconfigurable

{to change the shape or formation of;

stand solutions



1. Purchase your Modular stand –
Select from custom designs or have
a stand designed for you using
standard components



2. Re-configure your stand using existing
components or increase the size by
adding new sections



remodel; restructure}

Modular stands are flexible and re-usable. Purchase your stand just once and when you need to use it again simply re-configure the design selecting only the components required, or add to it to fit your new space and together with fresh graphics your stand will look completely different at a fraction of the cost!

Reconfigurable

3. Update your graphics to create a brand new look from your existing stand



<9m² stands

- Standard configurations up to 9m²
- Packed in bags or crates
- Self-assembly



>0.25 day



>2 people

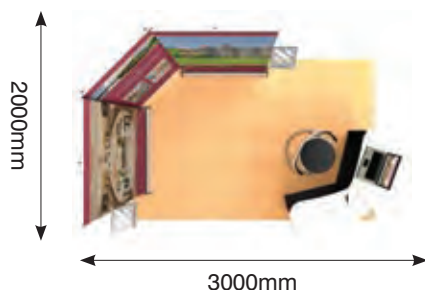

Cost effective and interesting way of creating an exhibition stand using Linking banner kits.

Create a large area for your message at a fraction of the cost using two Premium roller banners with a suspended graphic in between.

Complete the area using an Oyster case which converts into a large table top counter with storage and shelving within.

Constructed using Premium roller banners with banner linking kit



> Assembly time
Less than 0.25 day



> Based on 1
person assembly

Hardware weights and cases required



Hardware weight: 56kg approx



Hardware cases: 1 x 56kg Oyster moulded case

*Based on Barracuda banner



Formulate is a quick and easy stand system that looks spectacular with its sweeping lines and large visual graphic area.

The back walls are aluminium structures which are easy to assemble with fabric graphic socks that fit snugly around the frame.

Add Funky shapes that clip onto the back wall with specially designed clamps, add a smaller formulate table top version for further detail. With exciting imagery these stands can really give the wow factor for minimal investment.

All frames can hold optional low voltage lighting and all are supplied in a carry bag for transportation.

Constructed using Formulate back wall and Ladder Funky Shape.

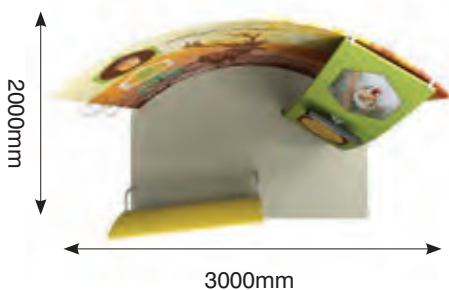

> Assembly time
Less than 0.25 day



> Based on 1
person assembly

Hardware weights and cases required



Hardware weight: 18kg approx



Hardware cases: 1 x 7kg, 1 x 6.5kg, 1 x 4.5kg



Stealth is a modular, linkable banner system designed to create seamless graphic displays, providing a highly portable and easy-to-use backdrop for all types of applications.

Link four banners together with magnetic strips and joining panels, position at different angles to suit your space.

Graphic panel can be cut out to support tv monitor, attach lights overhead. Complete display with counter to welcome your guests.

Constructed using four Stealth banners.



> Assembly time
Less than 0.25 day



> Based on 1
person assembly

Hardware weights and cases required



Hardware weight: 76kg



Hardware cases: 2 x counter bags, 1x standard 1050x550x160 bag
2 x padded bags for lights, 2 x 7.2kg Stealth cases



Pop-up displays are aptly named as they pop up and click into place using magnetic locking arms, graphics are attached using mag bars.

Displays can be as simple as you want or create large exhibition areas at a very cost effective price.

Connect three frames together with linking panels to create a flowing design complete with centre cut out and tv monitor.

For extra impact and height add a four quad Pop-up tower; for storage and shelving there is also a Pop-up counter available.

Constructed using three Pop-up frames and Pop-up tower.

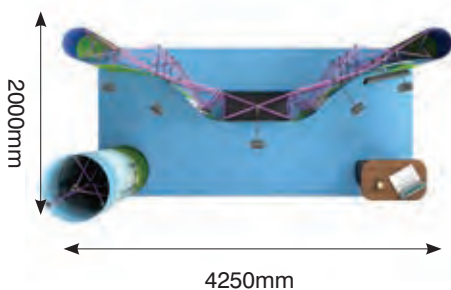

> Assembly time
Less than 0.5 day



> Based on 1
person assembly

Hardware weights and cases required



Hardware weight: 53kg



Hardware cases: 1 x 15kg Elipse moulded case
2 x 15kg Zeus moulded case
1 x Pop-up counter bag

9-12m² stands

- Standard configurations from 9m² - 12m²
- Packed in bags or crates
- Self-assembly



> 1 day



> 2 people

9-12m² Stands



Single back wall, open on three sides. A basic stand design to suit the cost conscious pocket whilst offering a smart stand solution.

The plain yet spacious back wall allows for literature shelving, poser table, tv monitor and lighting.

As there is only a single back wall this allows plenty of floor space for a counter and chair to welcome guests

Constructed from Linear vector with magnetic tape and PVC graphics.

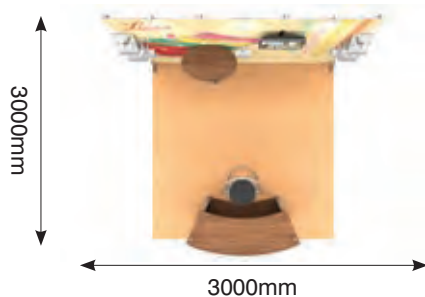

> Assembly time
0.25 day



> Based on 1
person assembly

Hardware weights and cases required



Hardware weight: 33kg approx



Hardware cases: 1 x 19kg, 1 x counter bag





Open on two sides this stand has plenty of space for a bar table and stools, poser table plus a welcome counter.

The sharp design also allows for literature shelves on the edges of the stand and over panel lighting.

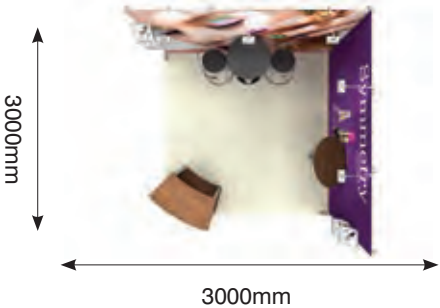
Constructed from Linear vector with magnetic tape and PVC graphics.



 > Assembly time
0.5 day

 > Based on 1
person assembly

Hardware weights and cases required

 **KG** Hardware weight: 33kg approx

 Hardware cases: 1 x 19kg, 1 x counter bag

9-12m² Stands

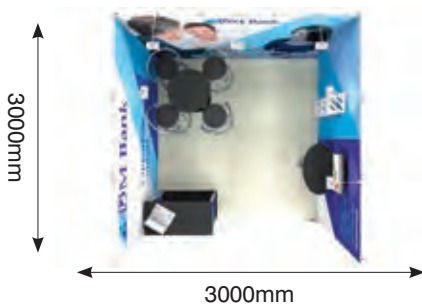

A U shaped stand design with three walls and open at the front, offering a little more privacy from neighbouring exhibitors.

The design still allows space for table and four chairs, a poser table and a welcome counter.

The straight walls offer plenty of area for tv monitors and literature racking plus plenty of overhead lighting.

Constructed from Linear vector with magnetic tape and PVC graphics



> Assembly time
0.5 day



> Based on 2
people assembly

Hardware weights and cases required



Hardware weight: 60kg approx



Hardware cases: 1 x 7kg case, 1 x 19kg, 1 x counter bag





Simple yet interesting design. Free-standing recessed cube with shelving and suspended acrylic poster holders.

Use striking imagery for the back walls to draw the customer in. Open on three sides with cube style counter plus room for table and chairs.

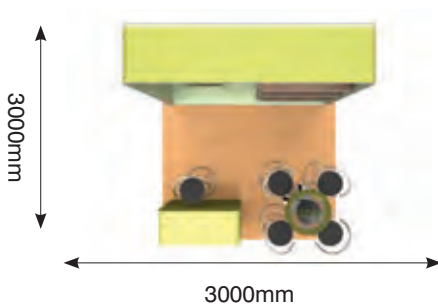
Constructed from Linear vector using textile fabric graphics



 > Assembly time
0.5 day

 > Based on 2
people assembly

Hardware weights and cases required

 **KG** Hardware weight: 180kg approx

 Hardware cases: 1 x 2kg case, 3 x 19kg

9-12m² Stands



Simple design with one shaped back wall, allowing easy access onto your stand.

Straight and curved panels allow for interesting multi dimensional graphics, use lighting for the ultimate effect.

With plenty of space for accessorising and room for a welcome counter, this is a very cost effective design for when you have limited space.

Constructed from Linear vector with PVC graphics

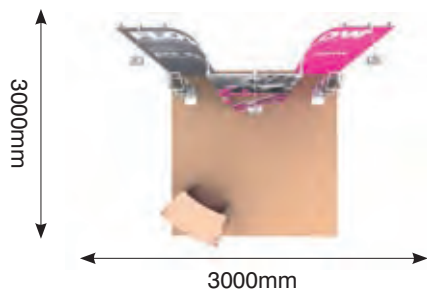

> Assembly time
0.5 day



> Based on 1
person assembly

Hardware weights and cases required



Hardware weight: 51kg approx



Hardware cases: 1 x 2.82kg case, 1 x 19kg, 1 x Counter Bag





Unusual and interesting stand design, open on two sides with centre meeting pod combining a storage cupboard and business seating area with room for four chairs and a table.

Complete with over panel lighting, literature holders and tv monitor.

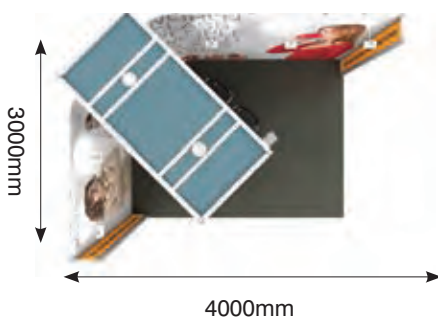
Constructed from Linear vector with PVC graphics



 > Assembly time
0.5 day

 > Based on 2
people assembly

Hardware weights and cases required

 **KG** Hardware weight: 126kg approx

 Hardware cases: 1 x 0.4kg case, 1 x 2kg case, 2 x 8.6kg, 3 x 19kg

9-12m² Stands



Eye-catching shaped display and counter which offers access from three sides.

Recessed alcoves providing space for acrylic shelves. Plenty of floor space allowing for large counter and literature stands

Constructed from Linear vector with textile fabric and PVC graphics

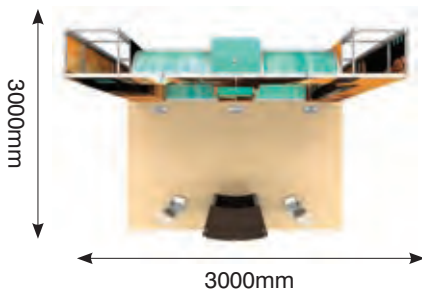

> Assembly time
1.0 days



> Based on 2
people assembly

Hardware weights and cases required



Hardware weight: 119kg approx



Hardware cases: 3 x 2.82kg, 1 x 5.24kg, 3 x 19kg,
1 x counter bag





Clever design which is open on three sides with a straight back wall. Large counters positioned close to back of the stand with plenty of counter space for monitors.

Tall Linear vector graphic panels are attached behind each counter for extra branding or graphics options. Floor is left clear and open welcoming customers onto the stand.

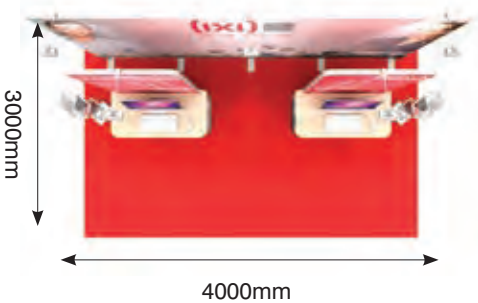

Constructed from Linear vector with textile fabric graphics



 > Assembly time 1.0 day

 > Based on 2 people assembly

Hardware weights and cases required

 **KG** Hardware weight: 102kg approx

 Hardware cases: 3 x 19kg

15-25m² stands

- Standard configurations from 15m² - 25m²
- Packed in bags or crates
- Self-assembly or professional install



>2 days



>2 people

15-25m² Stands



Attractive design open on two sides with tall end columns giving multi dimension to a simple design.

Plenty of room to add bar table and stools plus welcome counter and literature holders. Columns allow the mounting for TV monitors.

Constructed from Linear vector with textile fabric graphic

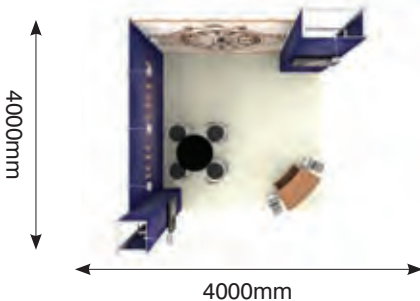

> Assembly time
1.0 day



> Based on 2
people assembly

Hardware weights and cases required



Hardware weight: 117kg approx



Hardware cases: 2 x 9kg, 3 x 19kg, 1 x counter bag





Open on two sides with straight back walls and corner section.

Design allows for integral shelving sheltered by two end panels offering a sense of privacy whilst on the stand. With plenty of room for a welcome counter and table and chairs, you can also accessorise with ambient lighting and tv monitors.

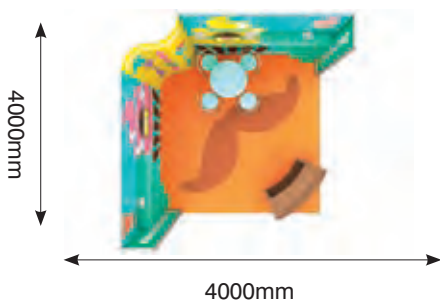
Constructed from Linear vector with PVC graphics



 > Assembly time
1.0 day

 > Based on 2
people assembly

Hardware weights and cases required

 **KG** Hardware weight: 134kg approx

 Hardware cases: 1 x 2kg case, 1 x 9kg, 3 x 19kg,
1 x counter bag

15-25m² Stands



Ultra modern stand with one main back wall with large feature panel in the centre to accommodate tv monitor which is flanked by two recessed shelving areas with hidden lighting.

Stand is open on three sides with two meeting areas at the front shielded from passers-by with two half height walls.

Constructed from Linear vector with textile fabric graphics

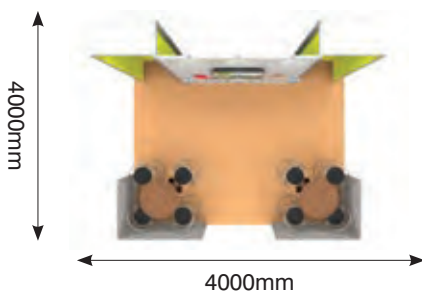

> Assembly time
1.0 days



> Based on 2
people assembly

Hardware weights and cases required



Hardware weight: 120kg approx



Hardware cases: 3 x 19kg





Interesting stand open on two sides with two tall arches that draw attention.

The design flow tempts your customers to walk through the archways, ideal for show casing artwork or information on the large back walls and pillar fronts. Room for table and chairs plus welcome counter, tv monitors and literature holders.

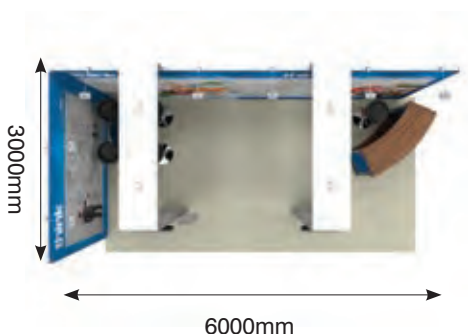
Constructed from Linear vector with textile fabric graphics



 > Assembly time
2.0 days

 > Based on 2
people assembly

Hardware weights and cases required

 **KG** Hardware weight: 104kg approx

 Hardware cases: 1 x 7kg case, 1 x 19kg, 1 x counter bag

Reconfigurable

{to change the shape or formation of;

stand solutions

1. Purchase base design with a single back wall with supported 'free-standing' shelving pods



2. Add extra panel to create a two sided stand using one of the shelving pods as a corner unit

remodel; restructure}



Perfect stand for re-configuring to suit different space options.

Stand can be redesigned to offer single back wall or open on two sides. Feature towers can be positioned at front of display or incorporated into back wall for extra shelving.

If space is more limited, components can be reduced by taking one of the towers away and using remaining one as part of back wall.

Very attractive design with plenty of shelving and seating options. Room for a counter in all three layouts.

Constructed from Linear vector with PVC graphics and in-fill graphic panels

Reconfigurable

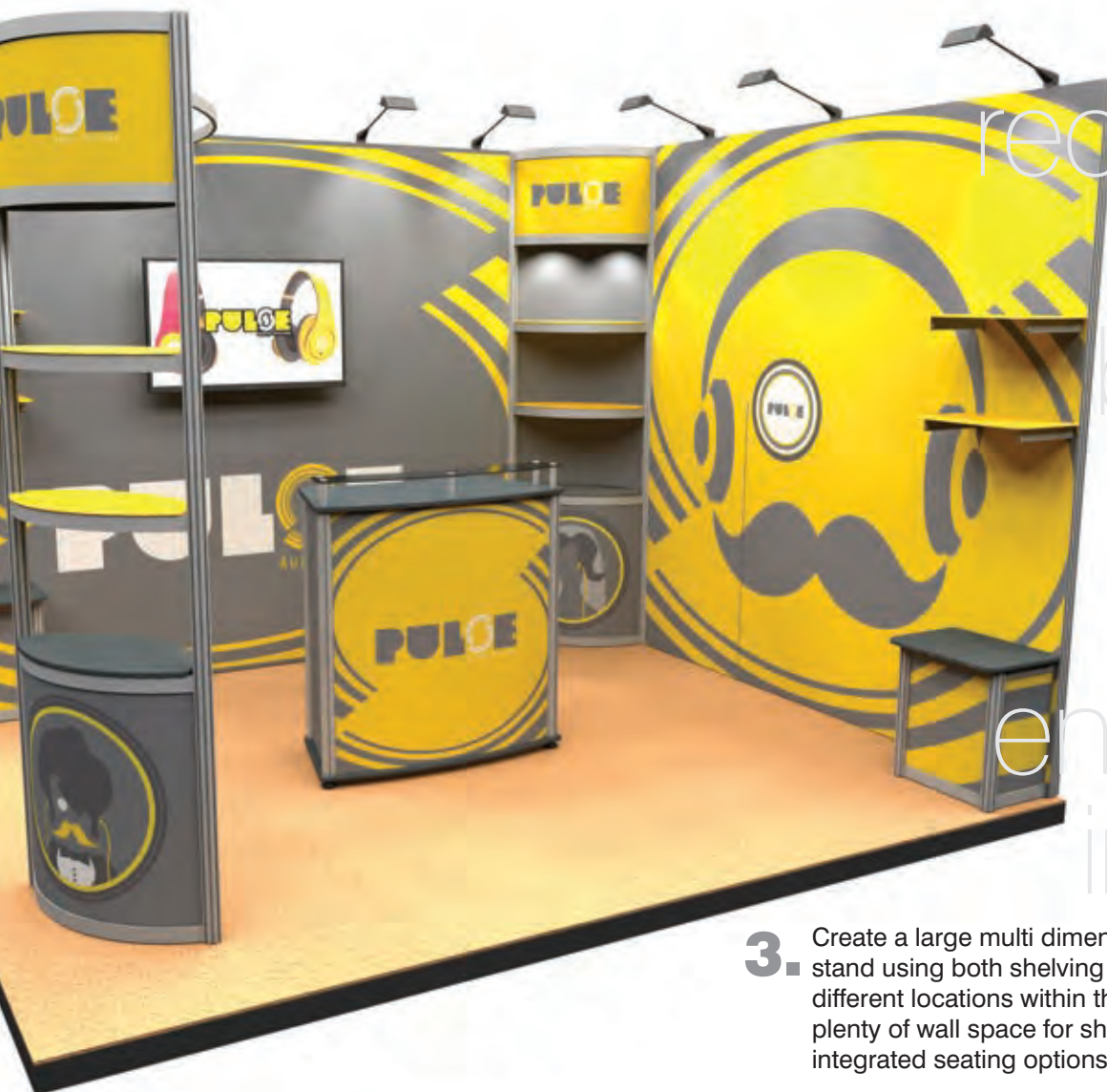

3. Create a large multi dimensional stand using both shelving pods in different locations within the design, plenty of wall space for shelving and integrated seating options

flounce
fluorine
graceful
refueling
careful
configure
courage
reconfigure
curable
pouncier
blurring
cerulean
encourage
incurable
figure
forge
ogre

30m² plus stands

- Standard configurations from 30m² plus
- Packed in bags or crates
- Professional install



>2 days



>4 people

30m² plus Stands





Large impressive stand for when you want to make an impact!

Open on two sides with added dimension using arches along the full length of the stand. Modern designed meeting area using acrylic and in fill panels which allows for a degree of privacy.

Large tower section with lighting for high-line branding. There is plenty of room for table and chairs plus arch panels allow for tv monitors. Further room at the front of the stand for display plinths.

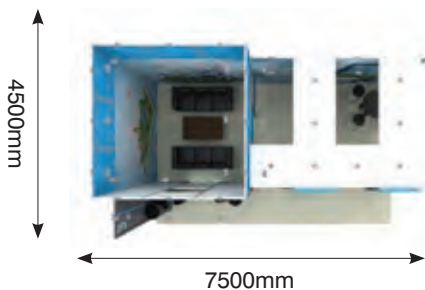
Constructed from Linear vector with textile fabric panels and acrylic in-fills.



 > Assembly time 2.0 days

 > Based on 3 people assembly

Hardware weights and cases required

 **KG** Hardware weight: 374kg approx

 Hardware cases: 2 x 9kg case, 9 x 19kg

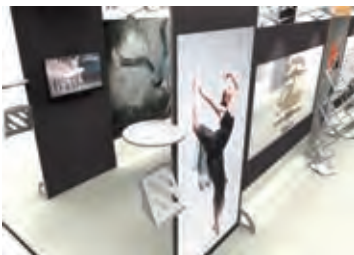



Large striking island stand with curved arches and lighted feature tunnel down the centre with walls either side for graphics or information.

Plenty of space on the outside for branding or presentation using the full length of the walls. Complete with tv monitors and literature holders for information.

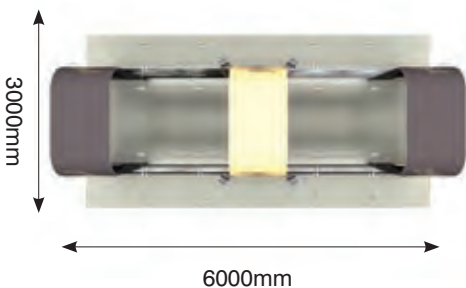
Constructed from Linear vector with textile fabric graphic panels.



 > Assembly time 2.0 days

 > Based on 2 people assembly

Hardware weights and cases required

 Hardware weight: 83kg approx

 Hardware cases: 3 x 9kg case, 2 x 19kg

1. Storage tower is positioned at the back of the stand and two of the graphic legs are used. Room for counter, tv monitor and literature holder. Branded hanging structure overhead.



2. Re-configure centre tower into a back wall with three graphic legs coming off it allowing a tunnel effect. Position counter at the front of the stand to greet customers. Hanging structure overhead





design service

Impressive designed island stand with large hanging structure above offering excellent branding and awareness opportunities.

High impact stand with some smart ways to reconfigure. Centre tower can be re-shaped into a back wall; use two, three or four of the graphic legs depending on space. All designs incorporate a welcome counter, literature holders and tv monitors.

For maximum exposure all three designs have a Formulate hanging structure making sure your stand is seen from all corners of the exhibition hall.



- 3.** Using all components to create a stunning island design complete with large hanging structure over head.



Package Type, Weights & Dimensions

 > Hardware weight: 136kg approx

 > Cases: 1 x 9kg case, 4 x 19kg

MATERIAL 1

t3

lite and flexi

t3 lite and flexi curve kits

t3 Lite and t3 flexi curve offer an easy to build, compact and flexible modular framework system manufactured in the UK. Design and build your stand from a wide range of standard components.

THE EASY BUILD

t3 lite and flexi curve kits features at a glance:



Neat corner and end trims

TV mounts

Graphics attached with magnetic tape

Curved and straight panels

Stand alone structures







t3 framework:

Creating eye-catching displays with smooth curves using the unique t3 flexi system.

All the stands are very simple to assemble using a straight forward Twist and Lock mechanism with no tools necessary.

Graphics fit smoothly and easily onto the frames using graphic hangers and magnetic edging.

t3 is ideal for:

-  Exhibition stands
-  Pop-up shops
-  Display graphics
-  POS displays
-  Conferences
-  Customer self build
-  Schools and colleges

D STAND SYSTEM

flexi curve structures:

easy to build from standard kits:

Start your t3 structure with any of the panels illustrated below and just add on until your design is complete. It's as simple as that.



Strasbourg



Toulouse



Monte Carlo



Nantes



Le Harve

t3 stands:

some of the great t3 stands available:

Choose from a range of stand designs or working with our 3D Design team create a T3 stand that fits your requirements perfectly

t3 accessories:

t3 comes with a great range of optional accessories:

accessories include standard table tops, shelving systems, monitor and light brackets, counters and cupboard storage solutions

Find out more at

MATERIAL 2

linear vector

linear vector

A flexible and durable stand system, linear vector is the perfect solution for your exhibition display.

Each design can provide seamless graphics using either textile fabric graphic, rollable or rigid medias which allows your artwork to flow uninterrupted across your stand.







Complete the look with a choice of accessories including spot lights, LCD brackets, literature holders, tablet holders and tables.

building big

linear vector features at a glance:



linear vector framework:

-  High quality stand solution
-  Reconfigurable
-  Easy to build
-  Wall frames are available in LED back lit versions
-  Exhibition stand kits also available
-  Durable with Lifetime guarantee

linear vector graphics:

-  Support a choice of graphic fixings including rigid, rollable, spring clip and silicon edged textile fabric
-  Seamless single or double sided graphic walls available
-  LED back lit panels available for textile fabric graphics

er has never been easier

linear vector fixings and accessories

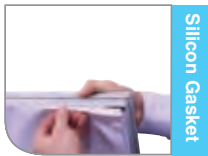

Silicon Gasket



Steel/Mag tape*



Looped

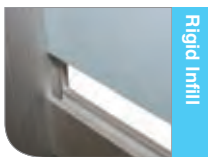

Rigid Infill



Acrylic Stacks
LN601-LCA

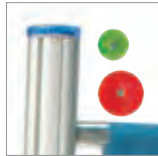

Fluorescent Acrylic Top Caps
Available in red, green or blue and in three shapes.

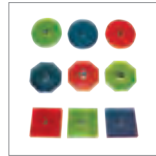

Engraved Thermoformed top
Custom Item



UV Printed table tops



Poser Table
LN319



Top Caps



PVC wing extrusion
LN608-1000



Thermoformed Base



Oval Base
LN114-S



450mm Steel Dome Base
LN102



Aluminium literature holder - LN112



Compass graphic fixing
LN502



Acrylic literature holder
LN501



Slatwall Panel
LN-SL-1000 x 750
Slatwall Leaflet Holder
(A4) AH310
Slatwall Hook AH321



Powerspot 1000
PS1000 (Vector light fitting)



Powerspot 1060 LED
Floodlight - PS1060S



LCD Brackets
3 types available



iPad holder 360°
See page 89

Posts



50mm 8-way
LN618

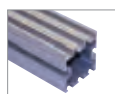

50mm square
8-way
LN616



75mm 8-way
LN8W



45mm
LN605



50mm oval
beam
LN609

Beams

Wooden Crates



*Steel / mag tape is supplied as standard with kits, please specify alternative graphic fixing if required (spring clip fixings will incur an additional charge) Thermoformed available in black, walnut, white, birch and silver

MATERIAL 3



vector lite

Vector lite is *the* economical 'hybrid' solution to support every type of graphic required within a small to medium exhibition stand design.

Made from anodised aluminium, Vector lite frame kits are available in standard sizes that can be used on their own or linked together.

This clever system supports rollable, foam, pvc and textile fabric graphics all in one unique extrusion!

fast and light

vector lite

features at a glance:

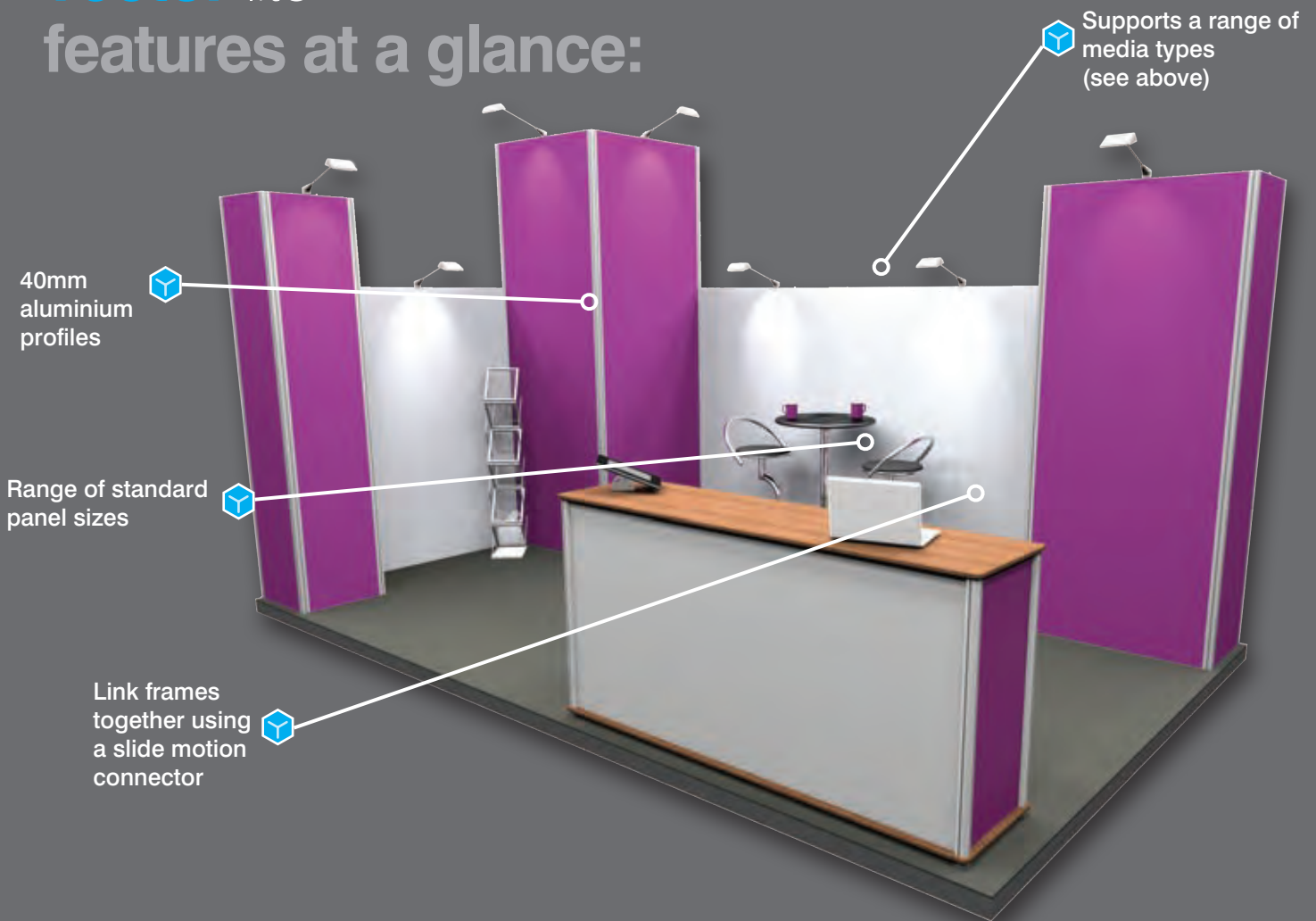

vector lite is ideal for:

- Exhibitions
- Conferences
- Easy self build
- Schools and colleges
- Retail environments
- Fast modular solutions

vector lite graphics:

- Seamless textile fabric
- Rollable media 0.5mm thickness
- Rigid media 2 or 3mm thickness

vector lite graphic fixings and frames



Steel/Mag tape*

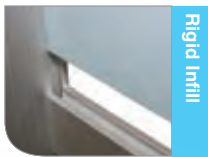

Rigid Infill



Silicon Gasket



vector lite graphic fixings and frames

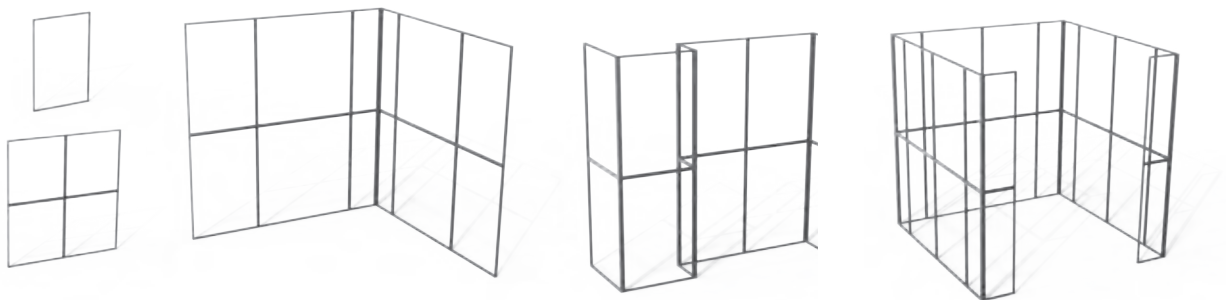

*Steel / mag tape is supplied as standard with kits, please specify alternative graphic fixing if required (spring clip fixings will incur an additional charge) Thermoformed table tops available in black, white, birch, silver and walnut.

MATERIAL 4

formulate

Formulate hanging structures are constructed from tough aluminium tubes with textile fabric graphic socks complete with steel eyelets that fit snugly around the frame using strong hook and loop fastening.

Formulate back walls and 'Funky Shapes' create dramatic back drops for your exhibition using simple tubes that lock into place, complete with graphic fabric socks secured by hook and loop

formulate

lightweight high

formulate system features at a glance:

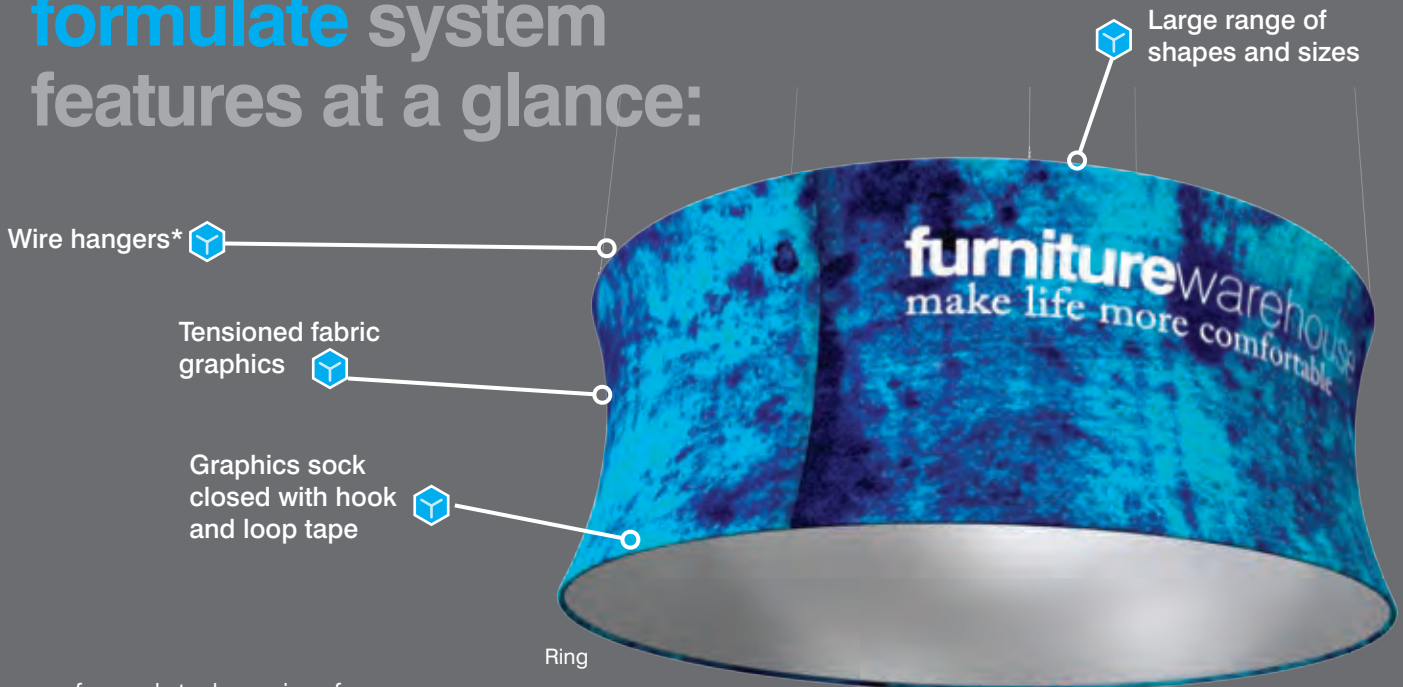

formulate hanging frames

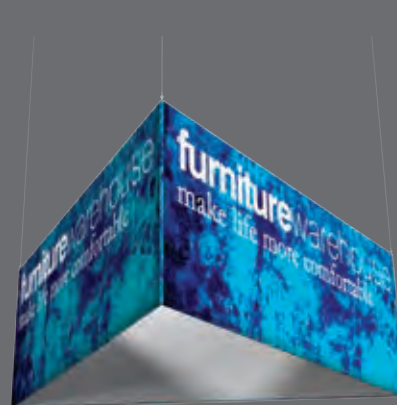
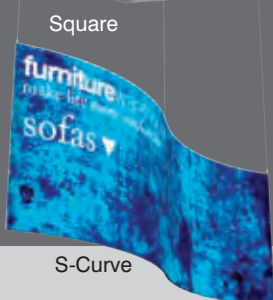
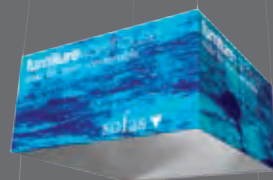

formulate is ideal for:

- Exhibition displays
- Conferences
- Customer self build
- Schools and colleges
- Retail environments
- High visual impact

formulate graphics:

Powerstretch, 215gsm fabric for indoor use giving a fully wrapped graphic with great tension due to the elastic qualities of the material

impact structures

formulate back walls and funky shapes (sold separately)



take a look at some of the great formulate structures available:

Choose from three back walls, Horizontal Curve, Vertical Curve and Straight. Add funky shapes to give a striking 3D effect to your stand.

funky shapes (sold separately)



MATERIAL5 formulate lite

formulate lite

Looking for a sharp, simple, portable fabric backwall that sets up in 5 minutes? Look no further.

The Formulate Lite back drop is one of the easiest and most portable solutions you can find.

In addition to the standard landscape/horizontal configuration, Formulate Lite can be turned on its side to create a portrait/vertical wall as well.

The sturdy, lightweight 30mm aluminum frame assembles with push-button functionality.

lightweight high

formulate lite system features at a glance:

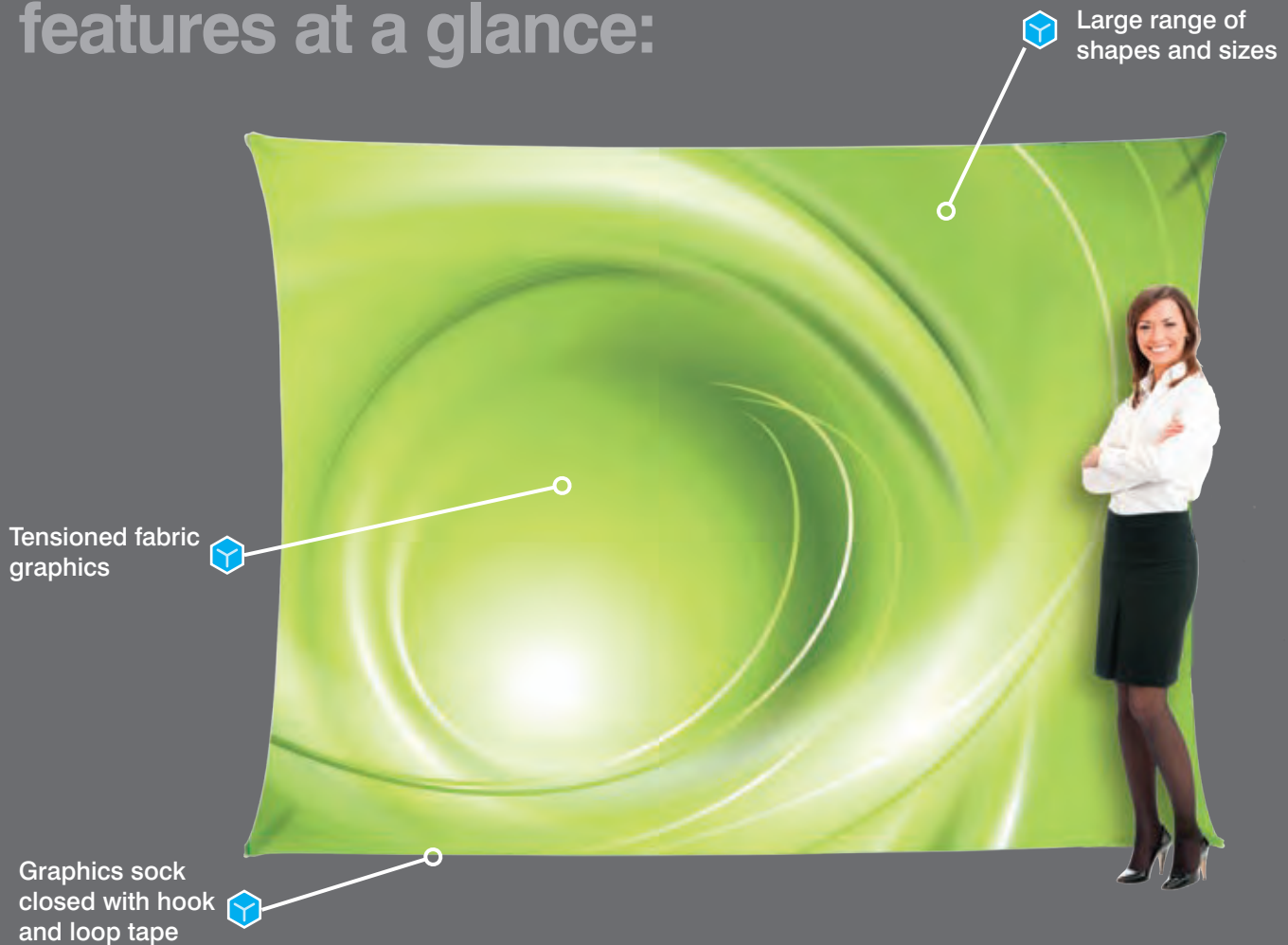

formulate lite is ideal for:

- Conferences
- Customer self build
- Schools and colleges
- Retail environments
- High visual impact

formulate lite features:

- Takes less than 5 minutes to set up
- Easy to store and ship
- Configures to portrait or landscape
- Kit includes: one frame, one dye-sublimated stretch fabric graphic and carry bag
- Storage carry case available as option

impact structures

take a look a closer look at our all new **formulate lite** - the five minute backwall:

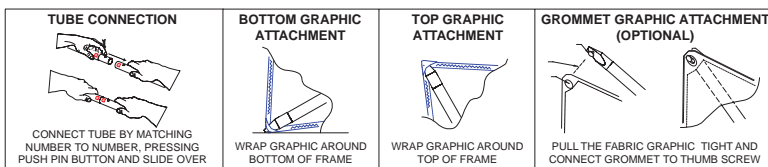
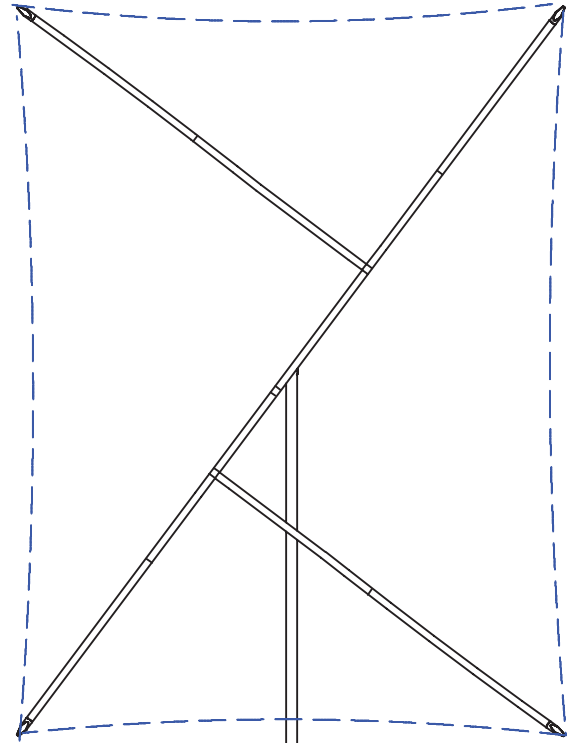
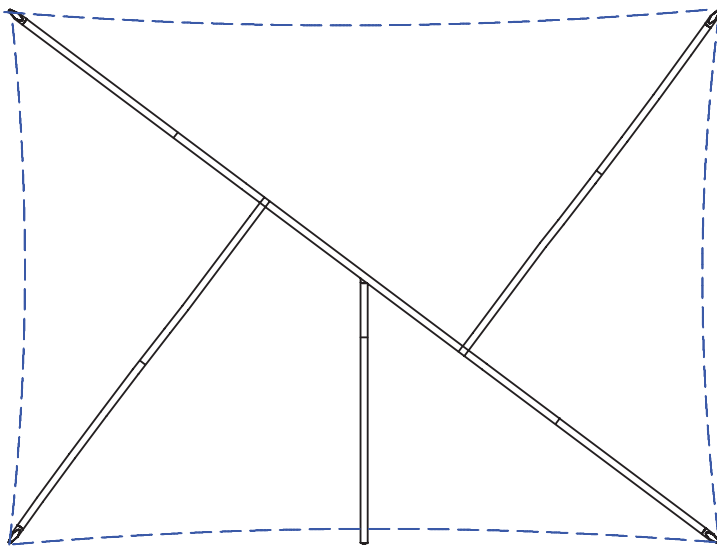

MATERIAL 6

panel & pole

panel & pole

Panel and Pole systems can be used to create a variety of stand designs using these well liked traditional structures.

With a choice of framed or frameless panels your options are endless and accessories can include lockable doors, curved panels, tabletops plus lots more and with these panels being durable and adaptable they are the perfect system for when you want to re-configure your design in the future.

simple and easy

panel & pole system features at a glance:

panel & pole is ideal for:

- Portable display systems
- Schools and colleges
- Room dividers
- Exhibitions
- Conferences

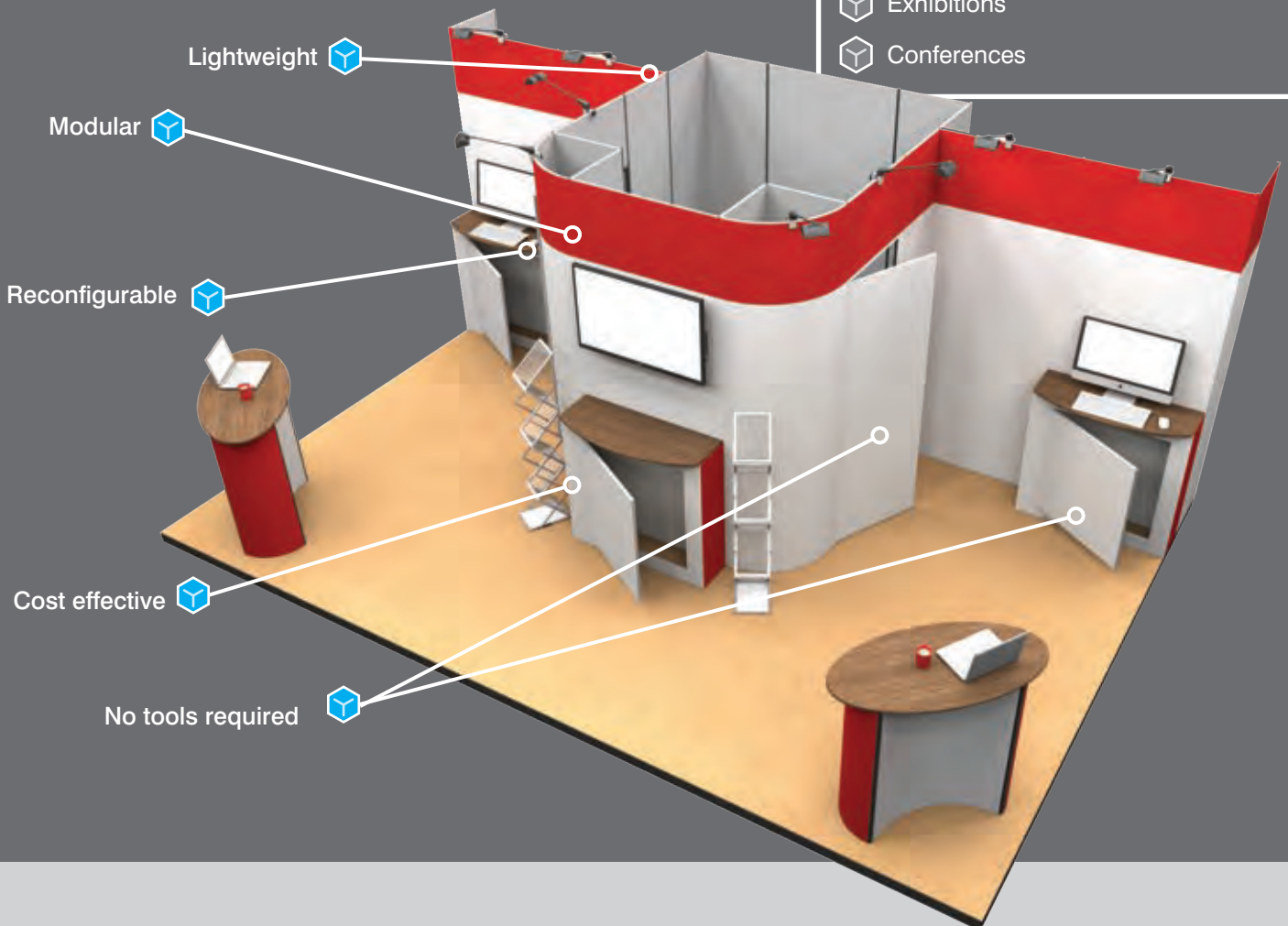

arena4 gantry

This type of system is ideal for creating very bold and striking exhibition stands.

With exposed lightweight aluminium beams that are extremely strong allowing a load bearing span of up to 60m.

There is plenty of scope to accessorise Arena 4 Gantry stands with table tops, literature holders and LCD monitor brackets.

easy to use

arena4 gantry

arena4 gantry system features at a glance:

arena4 gantry is ideal for:

- Exhibitions
- Showrooms
- Events
- Retail displays
- Hanging structures

